

**APEX DYNAMICS, INC.**

**PLANETARY GEARBOX  
NEW GENERATION P-SERIES  
PSII / PEII / PAII / PGII  
PSIIR / PEIIR / PAIIR / PGIIR**

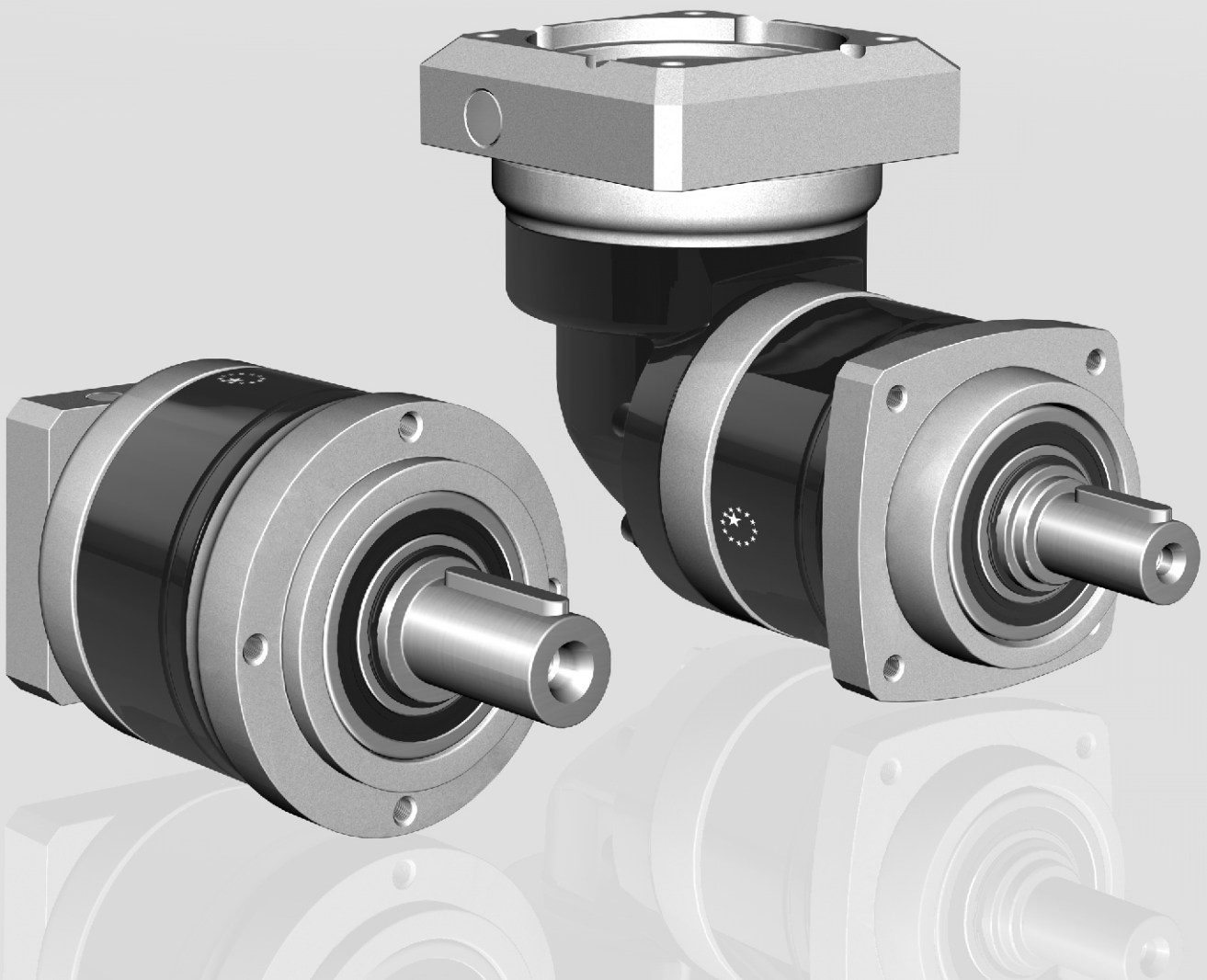

# Planetary Gearbox Series

## ► Features:

- Economic**
- High efficiency**
- Low noise**
- Reduced backlash**
- Optimized Inertia moment**
- Limited temperature rise**
- Long service life**
- Flexible mounting diameters**
- Minimized size and weight**

**T**he perfect servo planetary gearbox !

The brand new APEX PII / PIIR series. The PII / PIIR series is an economic high precision planetary gearbox with excellent performance and quality. Our innovative PII / PIIR series design features minimal size, light weight and high efficiency.

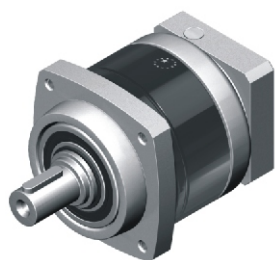

**PSII**



**PEII**

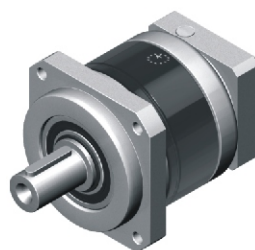

**PAII**

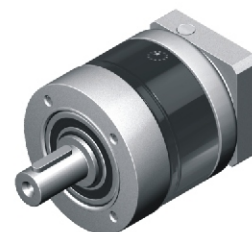

**PGII**

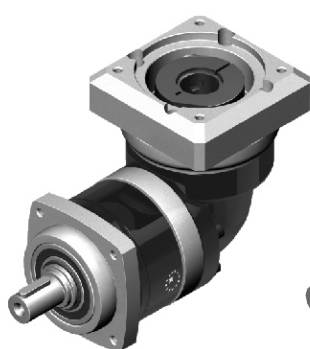

**PSIIR**

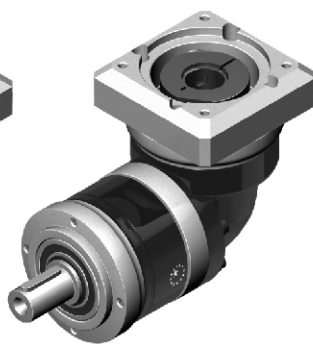

**PEIIR**



**PAIIR**

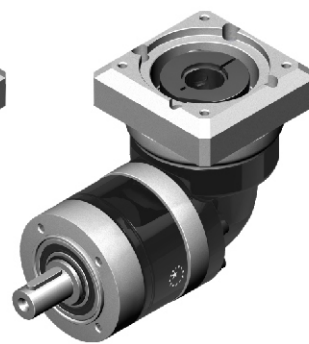

**PGIIR**

# ORDERING CODE

**PEII 090** — **010<sup>(1)</sup>** — **( )<sup>(2)</sup>** / **MOTOR**

**PEIIR 090** — **010<sup>(1)</sup>** — **( )<sup>(2)</sup>** / **MOTOR**

Motor Type :  
Manufacturer and Model

Ratio<sup>(1)</sup>:

1-stage: 3, 4, 5, 7, 9<sup>(3)</sup>, 10

2-stage: 15, 16, 20, 25, 30, 35, 40, 50, 70, 81<sup>(3)</sup>, 100

Gear Size:

**PSII: PSII A, PSII B, PSII C, PSII D, PSII E**

**PAII: PAII 042, PAII 060, PAII 090, PAII 115, PAII 142**

**PEII: PEII 050, PEII 070, PEII 090, PEII 120, PEII 155**

**PGII: PGII 040, PGII 060, PGII 080, PGII 120, PGII 160**

Ordering Example : **PEII090 - 010 / SIEMENS 1FT6 041 - 4AF71**  
**PAII090 - 010 - S1 / SIEMENS 1FT6 041 - 4AF71**

Gear Size:

**PSIIR: PSIIR A, PSIIR B, PSIIR C, PSIIR D, PSIIR E**

**PAIIR: PAIIR 042, PAIIR 060, PAIIR 090, PAIIR 115, PAIIR 142**

**PEIIR: PEIIR 050, PEIIR 070, PEIIR 090, PEIIR 120, PEIIR 155**

**PGIIR: PGIIR 040, PGIIR 060, PGIIR 080, PGIIR 120, PGIIR 160**

Ordering Example : **PEIIR 090 - 010 / SIEMENS 1FT6 041 - 4AF71**  
**PAIIR 090 - 010 - S1 / SIEMENS 1FT6 041 - 4AF71**

(1) Ratio ( $i = N_{in} / N_{out}$ ).

(2) S1 = Smooth Output Shaft. S1 shaft is only provided for PAII / PAIIR series.

S2 = Output Shaft with Key. This is the standard shaft for PII / PIIR gearbox.

(3) Only provided for PSII/PSIIR and PAII / PAIIR series.

# PII Gearbox Performance

Model No.	Stages	Ratio <sup>(1)</sup>	Type	PSII A	PSII B	PSII C	PSII D	PSII E	
				PEII 050	PEII 070	PEII 090	PEII 120	PEII 155	
				PAII 042	PAII 060	PAII 090	PAII 115	PAII 142	
				PGII 040	PGII 060	PGII 080	PGII 120	PGII 160	
Nominal Output Torque $T_{2N}$	Nm	1	3	AII	16	42	110	217	430
			4	AII	16	42	113	223	440
			5	AII	15	40	118	220	435
			7	AII	12	35	96	198	366
			9 <sup>(2)</sup>	AII	8	24	60	125	273
			10	AII	10	27	68	155	295
		2	15	AII	15	40	109	213	424
			16	AII	16	42	116	228	452
			20	AII	16	42	116	230	454
			25	AII	15	40	123	228	450
	30		AII	15	40	108	212	422	
	35		AII	12	35	100	206	382	
	40		AII	16	43	117	232	459	
	50		AII	15	40	123	228	450	
	70	AII	12	35	100	206	382		
	81 <sup>(2)</sup>	AII	8	24	59	131	285		
	100	AII	10	27	70	162	308		
	Emergency Stop Torque $T_{2NOT}$	Nm	1,2	3~100	AII	3 times $T_{2N}$			
Max. Acceleration Torque $T_{2B}$	Nm	1,2	3~100	AII	$T_{2B} = 60\%$ of $T_{2NOT}$				
No Load Running Torque <sup>(5)</sup>	Nm	1	3~10	AII	0.05	0.1	0.4	0.8	2.5
		2	15~100	AII	0.05	0.1	0.3	0.4	0.8
Backlash <sup>(3)</sup>	arcmin	1	3~10	AII	$\leq 8$	$\leq 7$	$\leq 6$	$\leq 6$	$\leq 6$
		2	15~100	AII	$\leq 10$	$\leq 9$	$\leq 8$	$\leq 8$	$\leq 8$
Torsional Rigidity <sup>(5)</sup>	Nm/arcmin	1,2	3~100	PSII	0.6	1.5	6	10.5	18
				PEII	0.9	2.2	8	12	16
				PAII	0.9	2.2	8	12	16
				PGII	0.5	2	8	12	16
Nominal Input Speed $n_{1N}$	rpm	1,2	3~100	AII	4,500	4,000	3,600	3,600	2,500
Max. Input Speed $n_{1B}$	rpm	1,2	3~100	AII	8,000	6,000	6,000	4,800	3,600
Max. Radial Load $F_{2RB}$ <sup>(4)</sup>	N	1,2	3~100	PSII	840	1,290	1,510	3,780	5,420
				PEII	810	1,150	1,530	3,260	4,550
				PAII	810	1,150	1,530	3,470	4,640
				PGII	520	1,030	1,570	3,590	4,690
Max. Axial Load $F_{2aB}$ <sup>(4)</sup>	N	1,2	3~100	PSII	420	645	755	1,890	2,710
				PEII	405	575	765	1,630	2,275
				PAII	405	575	765	1,735	2,320
				PGII	260	515	785	1,795	2,345
Service Life <sup>(6)</sup>	hr	1,2	3~100	AII	20,000				
Operating Temp	°C	1,2	3~100	AII	0° C ~ +90° C				
Degree of Gearbox Protection		1,2	3~100	AII	IP65				
Lubrication		1,2	3~100	AII	Synthetic lubrication grease				
Mounting Position		1,2	3~100	AII	All directions				
Running Noise <sup>(5)</sup>	dB(A)	1,2		AII	$\leq 60$	$\leq 62$	$\leq 64$	$\leq 66$	$\leq 68$
Efficiency $\eta$	%	1	3~10	AII	$\geq 97\%$				
		2	15~100	AII	$\geq 94\%$				

(1) Ratio ( $i = N_{in} / N_{out}$ ).

(2) Ratio 9 and 81 are only provided for PSII and PAII series.

(3) Backlash is measured at 2% of Nominal Output Torque  $T_{2N}$ .

(4) Applied to the output shaft center at 100 rpm.

(5) These values are measured by gearbox with ratio = 10 (1-stage) or ratio = 100 (2-stage) at 3,000 rpm without load.

Under other conditions, this data will be different.

(6) For continuous operation, the service life time is less than 10,000 hrs.

© 2014 by APEX DYNAMICS, INC.

APEX DYNAMICS, INC. reserves modification and copy right of all technical specifications, illustrations and drawings in this catalog in allowance for continuous products development and advancement.

For the newest data and information, please visit [www.apexdyna.com/](http://www.apexdyna.com/)

# PII Gearbox Inertia

Model No.		PSII A		PSII B		PSII C		PSII D		PSII E	
		PEII 050		PEII 070		PEII 090		PEII 120		PEII 155	
		PAII 042		PAII 060		PAII 090		PAII 115		PAII 142	
		PGII 040		PGII 060		PGII 080		PGII 120		PGII 160	
$\varnothing^{(A)}$ (c3)		1-stage	2-stage	1-stage	2-stage	1-stage	2-stage	1-stage	2-stage	1-stage	2-stage
8	kg.cm <sup>2</sup>	0.10	0.10	0.10~ 0.12	0.10	-	-	-	-	-	-
11		0.16	0.16	0.16~ 0.19	0.16	-	-	-	-	-	-
14		0.19~ 0.20	0.19~ 0.20	0.20~ 0.22	0.20	0.20~ 0.36	0.20~ 0.24	-	-	-	-
19		-	-	1.51~ 1.53	1.51	1.54~ 1.70	1.54~ 1.58	1.60~ 2.20	1.60~ 1.73	-	1.69~ 2.18
24		-	-	-	-	2.09~ 2.24	2.09~ 2.12	2.14~ 2.74	2.14~ 2.27	2.23~ 4.52	2.23~ 2.73
28		-	-	-	-	2.52~ 2.68	2.52~ 2.55	2.57~ 3.17	2.57~ 2.70	2.65~ 4.94	2.65~ 3.15
32		-	-	-	-	-	-	7.17~ 7.77	7.17~ 7.30	7.41~ 9.70	7.41~ 7.91
35		-	-	-	-	-	-	10.20~ 10.80	10.20~ 10.30	10.50~ 12.80	10.50~ 11.00
38		-	-	-	-	-	-	13.40~ 14.00	13.40~ 13.50	13.70~ 16.00	13.70~ 14.20
42		-	-	-	-	-	-	-	-	22.20~ 24.50	-

(A)  $\varnothing$  = Input shaft diameter.

# PSII Series Dimension

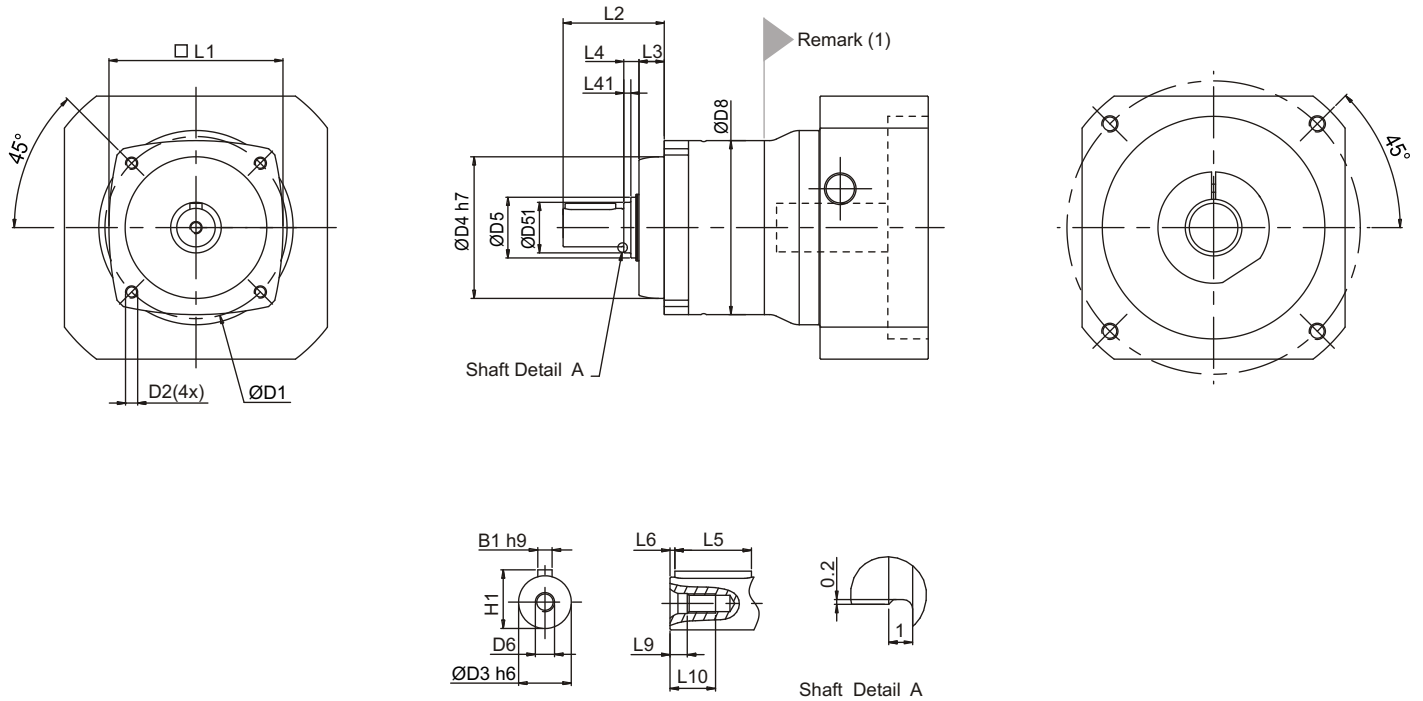

Dimension	PSII A		PSII B		PSII C		PSII D		PSII E	
	1-stage	2-stage	1-stage	2-stage	1-stage	2-stage	1-stage	2-stage	1-stage	2-stage
D1	47		60		90		115		135	
D2	M4X9		M5X10		M6X12		M8X18.5		M10X18	
D3	h6	10	12		19		24		32	
D4	h7	38	50		70		90		110	
D5		17	22		30		40		55	
D51		-	-		25		-		-	
D6	M3X0.5P		M4X0.7P		M6X1P		M8X1.25P		M12X1.75P	
D8		44	60		86		114		140	
L1		44	60		86		114		140	
L2		25	32		50		61		75	
L3		6.5	8.5		12.5		16		14.5	
L4		2.5	3.5		7.5		5		5.5	
L41		-	-		3.5		-		-	
L5		10	16		25		32		50	
L6		3	2		1		3		2	
L9		2.6	4.5		5		7.2		10	
L10		9	10		16.5		19		28	
B1	h9	3	4		6		8		10	
H1		11.2	13.5		21.5		27		35	

(1) Dimensions are related to motor interface. Please contact APEX for details.

# PEII Series Dimension

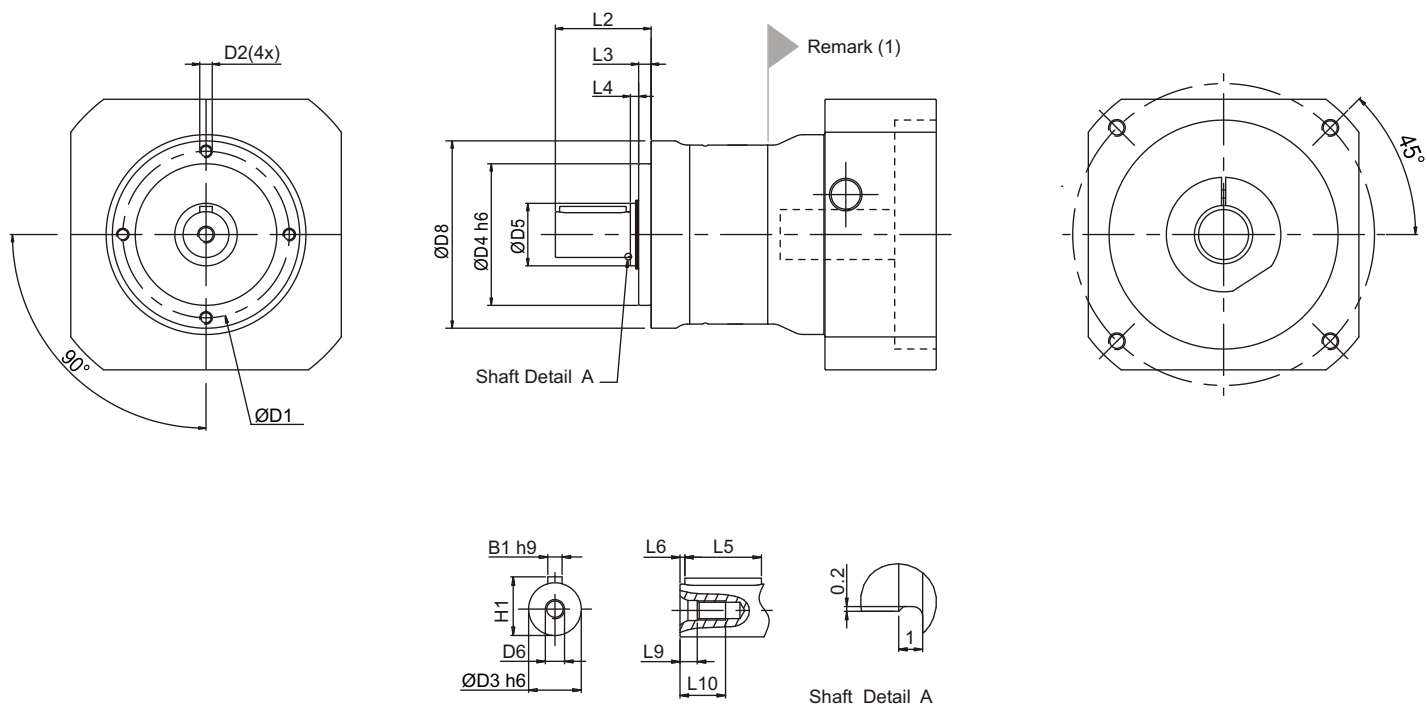

Dimension	PEII 050		PEII 070		PEII 090		PEII 120		PEII 155	
	1-stage	2-stage	1-stage	2-stage	1-stage	2-stage	1-stage	2-stage	1-stage	2-stage
D1	44		62		80		108		140	
D2	M4X9		M5X10		M6X12		M8X15		M10X18	
D3	h6	12	16		22		32		40	
D4	h6	35	52		68		90		120	
D5		17	22		30		40		55	
D6		M4X0.7P	M5X0.8P		M8X1.25P		M12X1.75P		M16X2P	
D8		50	70		90		120		155	
L2		24.5	36		46		70		97	
L3		4	4.5		6		7		9.5	
L4		2.5	3.5		4		5		5.5	
L5		14	25		32		50		70	
L6		2	2		2		4		6	
L9		4.5	4.8		7.2		10		12	
L10		10	12.5		19		28		36	
B1	h9	4	5		6		10		12	
H1		13.5	18		24.5		35		43	

(1) Dimensions are related to motor interface. Please contact APEX for details.

# PAII Series Dimension

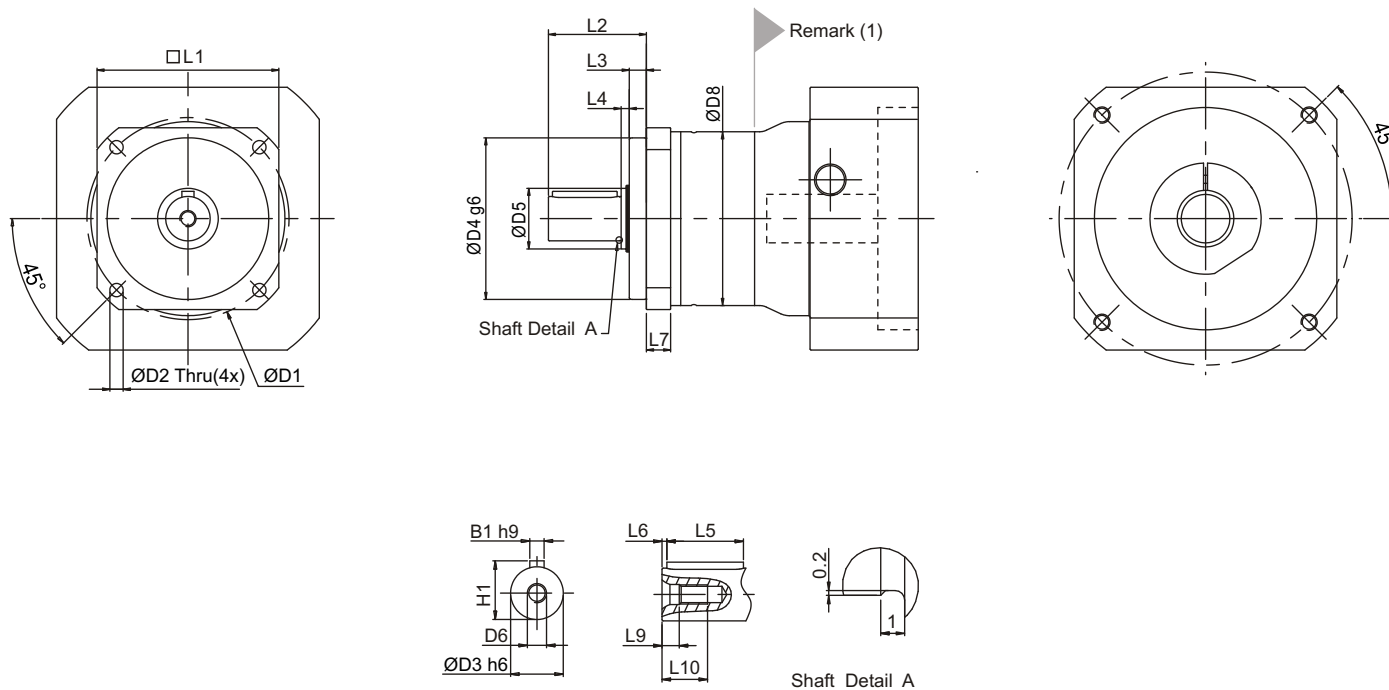

Dimension	PAII 042		PAII 060		PAII 090		PAII 115		PAII 142	
	1-stage	2-stage	1-stage	2-stage	1-stage	2-stage	1-stage	2-stage	1-stage	2-stage
D1	50		70		100		130		165	
D2	3.4		5.5		6.6		9		11	
D3 h6	13		16		22		32		40	
D4 g6	35		50		80		110		130	
D5	17		22		30		40		55	
D6	M4X0.7P		M5X0.8P		M8X1.25P		M12X1.75P		M16X2P	
D8	44		60		86		114		140	
L1	42		60		90		115		142	
L2	26		37		48.5		65		97	
L3	5.5		5.5		8.5		10		12.5	
L4	2.5		3.5		4		5		5.5	
L5	14		25		32		40		63	
L6	2		2		2		5		5	
L7	6.5		10		12		16		20	
L9	4.5		4.8		7.2		10		12	
L10	10		12.5		19		28		36	
B1 h9	5		5		6		10		12	
H1	15		18		24.5		35		43	

(1) Dimensions are related to motor interface. Please contact APEX for details.



# PGII Series Dimension

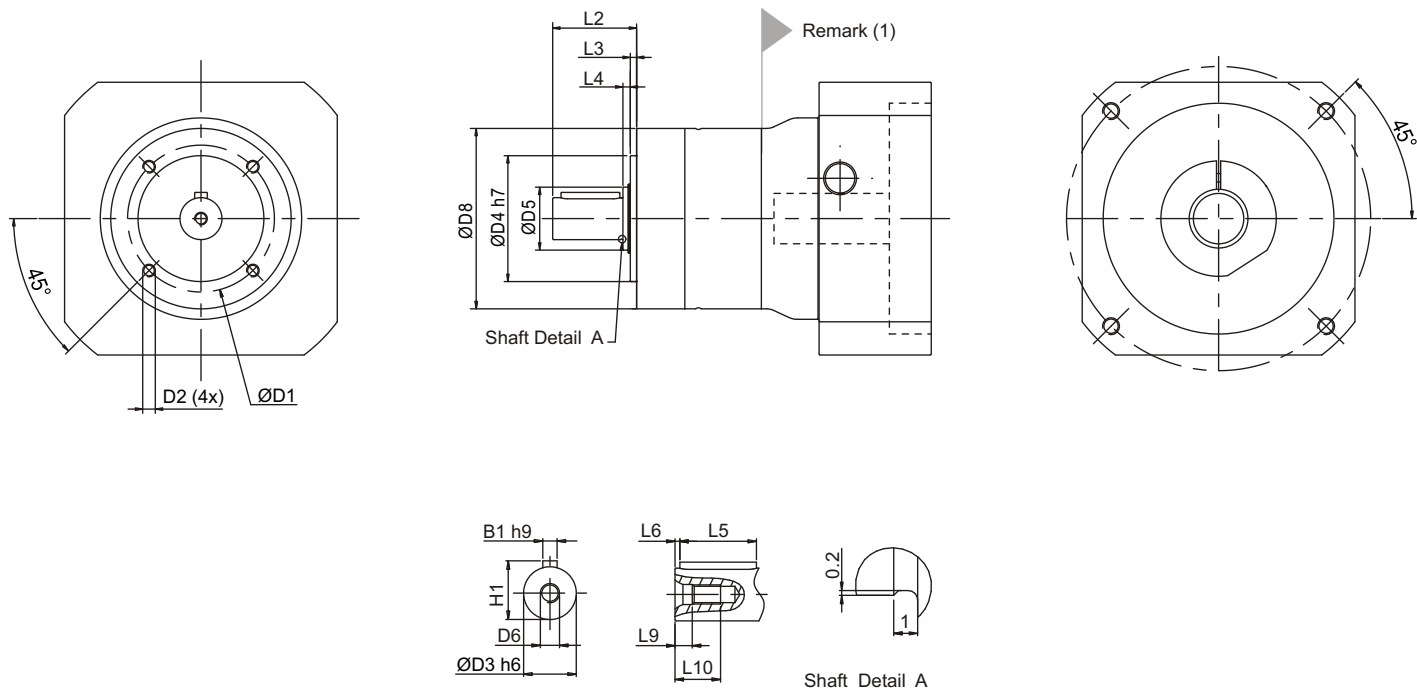

Dimension	PGII 040		PGII 060		PGII 080		PGII 120		PGII 160	
	1-stage	2-stage	1-stage	2-stage	1-stage	2-stage	1-stage	2-stage	1-stage	2-stage
D1	34		52		70		100		145	
D2	M4X9		M5X10		M6X12		M10X18		M12X22	
D3	h6	10	14	20	25	40				
D4	h7	26	40	60	80	130				
D5		17	17	30	40	55				
D6		M3X0.5P	M5X0.8P	M6X1P	M10X1.5P	M16X2P				
D8		44	60	86	114	160				
L2		26	35	40	55	87				
L3		2	3	3	4	5				
L4		1	2	3.5	5	5.5				
L5		18	25	28	40	65				
L6		2.5	2.5	4	5	8				
L9		2.6	4.8	5	7.5	12				
L10		9	12.5	16.5	22	36				
B1	h9	3	5	6	8	12				
H1		11.2	16	22.5	28	43				

(1) Dimensions are related to motor interface. Please contact APEX for details.

# PIIR Gearbox Performance

Model No.	Stages	Ratio <sup>(1)</sup>	Type	PSIIR A	PSIIR B	PSIIR C	PSIIR D	PSIIR E	
				PEIIR 050	PEIIR 070	PEIIR 090	PEIIR 120	PEIIR 155	
				PAIIR 042	PAIIR 060	PAIIR 090	PAIIR 115	PAIIR 142	
				PGIIR 040	PGIIR 060	PGIIR 080	PGIIR 120	PGIIR 160	
Nominal Output Torque $T_{2N}$	Nm	1	All	3	16	42	110	217	430
				4	16	42	113	223	440
				5	15	40	118	220	435
				7	12	35	96	198	366
				9 <sup>(2)</sup>	8	24	60	125	273
				10	10	27	68	155	295
		2		15	15	40	109	213	424
				16	16	42	116	228	452
				20	16	42	116	230	454
				25	15	40	123	228	450
				30	15	40	108	212	422
				35	12	35	100	206	382
				40	16	43	117	232	459
				50	15	40	123	228	450
				70	12	35	100	206	382
				81 <sup>(2)</sup>	8	24	59	131	285
				100	10	27	70	162	308
				Emergency Stop Torque $T_{2NOT}$	Nm	1,2	3~100	All	3 times $T_{2N}$
Max. Acceleration Torque $T_{2B}$	Nm	1,2	3~100	All	$T_{2B} = 60\%$ of $T_{2NOT}$				
No Load Running Torque <sup>(5)</sup>	Nm	1	3~10	All	0.1	0.15	0.45	0.85	2.55
		2	15~100		0.1	0.15	0.35	0.45	0.85
Backlash <sup>(3)</sup>	arcmin	1	3~10	All	$\leq 12$	$\leq 11$	$\leq 10$	$\leq 10$	$\leq 10$
		2	15~100	All	$\leq 14$	$\leq 13$	$\leq 12$	$\leq 12$	$\leq 12$
Torsional Rigidity <sup>(5)</sup>	Nm/arcmin	1,2	3~100	PSIIR	0.6	1.5	6	10.5	18
				PEIIR	0.9	2.2	8	12	16
				PAIIR	0.9	2.2	8	12	16
				PGIIR	0.5	2	8	12	16
Nominal Input Speed $n_{1N}$	rpm	1,2	3~100	All	4,500	4,000	3,600	3,600	2,500
Max. Input Speed $n_{1B}$	rpm	1,2	3~100	All	8,000	6,000	6,000	4,800	3,600
Max. Radial Load $F_{2RB}$ <sup>(4)</sup>	N	1,2	3~100	PSIIR	840	1,290	1,510	3,780	5,420
				PEIIR	810	1,150	1,530	3,260	4,550
				PAIIR	810	1,150	1,530	3,470	4,640
				PGIIR	520	1,030	1,570	3,590	4,690
Max. Axial Load $F_{2aB}$ <sup>(4)</sup>	N	1,2	3~100	PSIIR	420	645	755	1,890	2,710
				PEIIR	405	575	765	1,630	2,275
				PAIIR	405	575	765	1,735	2,320
				PGIIR	260	515	785	1,795	2,345
Service Life <sup>(6)</sup>	hr	1,2	3~100	All	20,000				
Operating Temp	°C	1,2	3~100	All	0° C ~ +90° C				
Degree of Gearbox Protection		1,2	3~100	All	IP65				
Lubrication		1,2	3~100	All	Synthetic lubrication grease				
Mounting Position		1,2	3~100	All	All directions				
Running Noise <sup>(5)</sup>	dB(A)	1,2		All	$\leq 70$	$\leq 72$	$\leq 74$	$\leq 75$	$\leq 77$
Efficiency $\eta$	%	1	3~10	All	$\geq 93\%$				
		2	15~100		$\geq 90\%$				

(1) Ratio ( $i = N_{in} / N_{out}$ ).

(2) Ratio 9 and 81 are only provided for PSII and PAII series.

(3) Backlash is measured at 2% of Nominal Output Torque  $T_{2N}$ .

(4) Applied to the output shaft center at 100 rpm.

(5) These values are measured by gearbox with ratio = 10 (1-stage) or ratio = 100 (2-stage) at 3,000 rpm without load.

Under other conditions, this data will be different.

(6) For continuous operation, the service life time is less than 10,000 hrs.

# PIIR Gearbox Inertia

Model No.		PSIIR A		PSIIR B		PSIIR C		PSIIR D		PSIIR E	
		PEIIR 050		PEIIR 070		PEIIR 090		PEIIR 120		PEIIR 155	
		PAIIR 042		PAIIR 060		PAIIR 090		PAIIR 115		PAIIR 142	
		PGIIR 040		PGIIR 060		PGIIR 080		PGIIR 120		PGIIR 160	
$\emptyset^{(A)}$ (C3)		1-stage	2-stage	1-stage	2-stage	1-stage	2-stage	1-stage	2-stage	1-stage	2-stage
8	kg.cm <sup>2</sup>	0.18	0.18	0.36	0.36	-	-	-	-	-	-
11		0.20	0.20	0.39	0.39	-	-	-	-	-	-
14		0.24	0.24	0.43	0.43	1.87	1.87	-	-	-	-
19		-	-	1.24	1.24	2.67	2.67	6.80	6.80	-	13.57
24		-	-	-	-	2.97	2.97	7.10	7.10	13.87	13.87
28		-	-	-	-	3.47	3.47	7.59	7.59	14.36	14.36
32		-	-	-	-	-	-	10.56	10.56	17.33	17.33
35		-	-	-	-	-	-	11.97	11.97	18.74	18.74
38		-	-	-	-	-	-	13.95	13.95	20.79	20.79
42		-	-	-	-	-	-	-	-	26.54	-

(A)  $\emptyset$  = Input shaft diameter.

# PSIIR Series Dimension

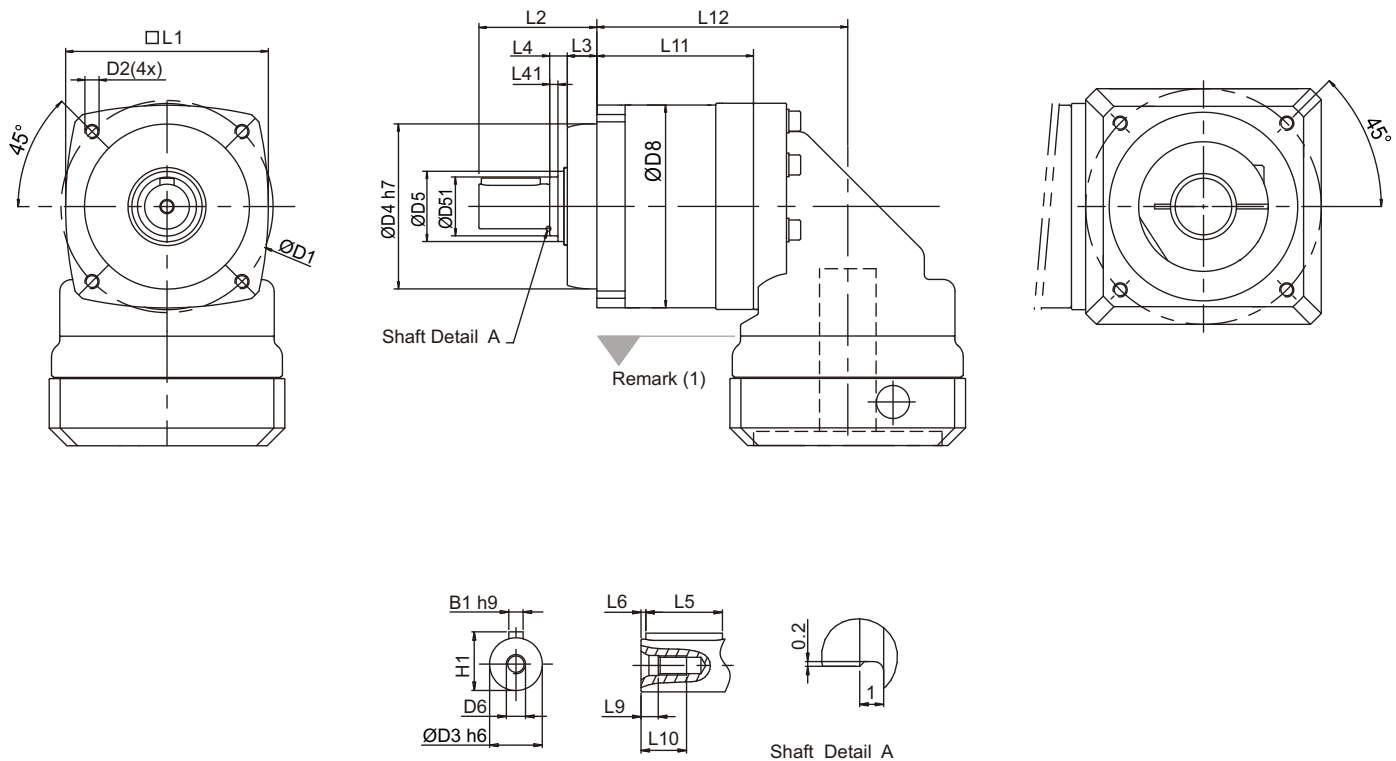

Dimension	PSIIR A		PSIIR B		PSIIR C		PSIIR D		PSIIR E		
	1-stage	2-stage	1-stage	2-stage	1-stage	2-stage	1-stage	2-stage	1-stage	2-stage	
D1	47		60		90		115		135		
D2	M4X9		M5X10		M6X12		M8X18.5		M10X18		
D3	h6	10	12	19	24	32					
D4	h7	38	50	70	90	110					
D5		17	22	30	40	55					
D51		-	-	25	-	-					
D6		M3X0.5P	M4X0.7P	M6X1P	M8X1.25P	M12X1.75P					
D8		44	60	86	114	140					
L1		44	60	86	114	140					
L2		25	32	50	61	75					
L3		6.5	8.5	12.5	16	14.5					
L4		2.5	3.5	7.5	5	5.5					
L41		-	-	3.5	-	-					
L5		10	16	25	32	50					
L6		3	2	1	3	2					
L9		2.6	4.5	5	7.2	10					
L10		9	10	16.5	19	28					
L11		47	62	56	76	66.5	93	92	128	116	163.5
L12		72	87	85.5	105.5	106.5	133	143	179	173	220.5
B1	h9	3	4	6	8	10					
H1		11.2	13.5	21.5	27	35					

(1) Dimensions are related to motor interface. Please contact APEX for details.

# PEIR Series Dimension

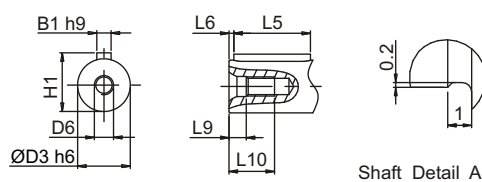
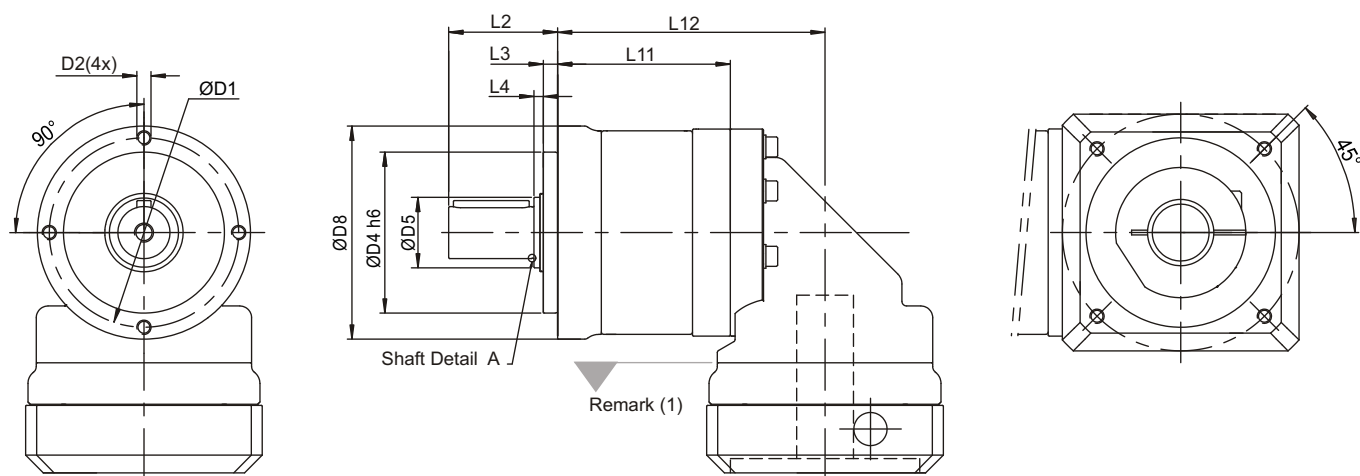

Dimension	PEIR 050		PEIR 070		PEIR 090		PEIR 120		PEIR 155	
	1-stage	2-stage	1-stage	2-stage	1-stage	2-stage	1-stage	2-stage	1-stage	2-stage
D1	44		62		80		108		140	
D2	M4X9		M5X10		M6X12		M8X15		M10X18	
D3	h6	12	16	22	32	40				
D4	h6	35	52	68	90	120				
D5		17	22	30	40	55				
D6	M4X0.7P		M5X0.8P		M8X1.25P		M12X1.75P		M16X2P	
D8	50		70		90		120		155	
L2	24.5		36		46		70		97	
L3	4		4.5		6		7		9.5	
L4	2.5		3.5		4		5		5.5	
L5	14		25		32		50		70	
L6	2		2		2		4		6	
L9	4.5		4.8		7.2		10		12	
L10	10		12.5		19		28		36	
L11	49.5	64.5	60	80	73	99.5	101	137	121	168.5
L12	74.5	89.5	89.5	109.5	113	139.5	152	188	178	225.5
B1	h9	4	5	6	10	12				
H1		13.5	18	24.5	35	43				

(1) Dimensions are related to motor interface. Please contact APEX for details.

# PAIIR Series Dimension

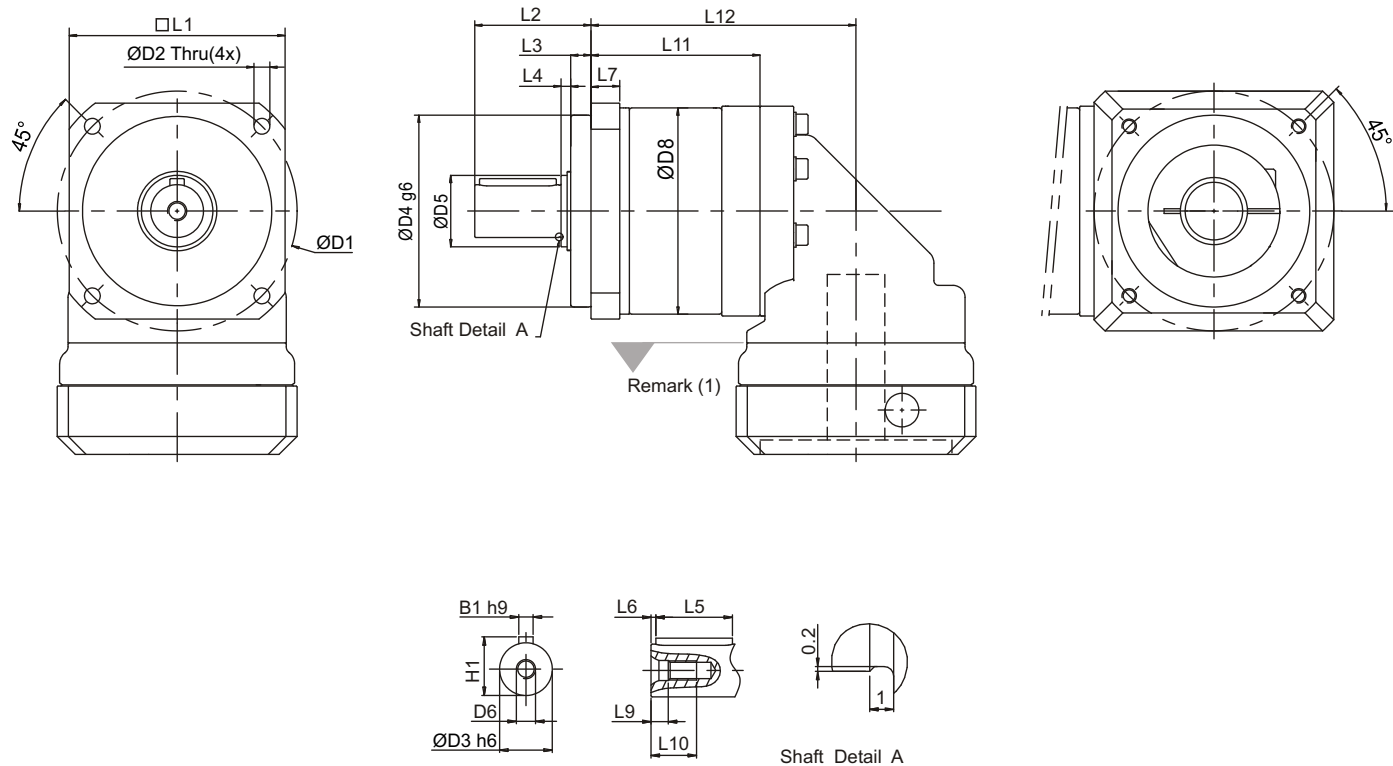

Dimension	PAIIR 042		PAIIR 060		PAIIR 090		PAIIR 115		PAIIR 142	
	1-stage	2-stage	1-stage	2-stage	1-stage	2-stage	1-stage	2-stage	1-stage	2-stage
D1	50		70		100		130		165	
D2	3.4		5.5		6.6		9		11	
D3 h6	13		16		22		32		40	
D4 g6	35		50		80		110		130	
D5	17		22		30		40		55	
D6	M4X0.7P		M5X0.8P		M8X1.25P		M12X1.75P		M16X2P	
D8	44		60		86		114		140	
L1	42		60		90		115		142	
L2	26		37		48.5		65		97	
L3	5.5		5.5		8.5		10		12.5	
L4	2.5		3.5		4		5		5.5	
L5	14		25		32		40		63	
L6	2		2		2		5		5	
L7	6.5		10		12		16		20	
L9	4.5		4.8		7.2		10		12	
L10	10		12.5		19		28		36	
L11	48	63	59	79	70.5	97	98	134	118	165.5
L12	73	88	88.5	108.5	110.5	137	149	185	175	222.5
B1 h9	5		5		6		10		12	
H1	15		18		24.5		35		43	

(1) Dimensions are related to motor interface. Please contact APEX for details.

# PGIIR Series Dimension

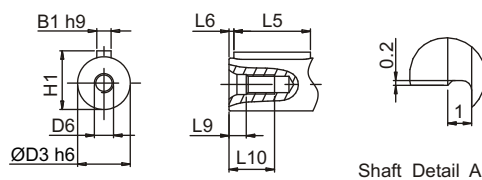
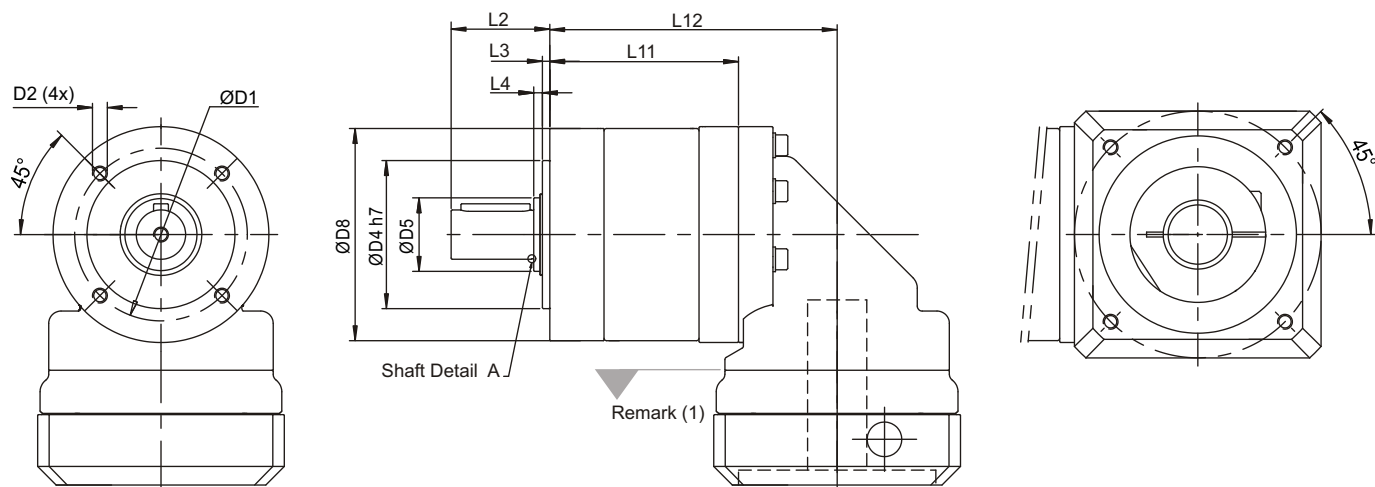

Dimension	PGIIR 040		PGIIR 060		PGIIR 080		PGIIR 120		PGIIR 160	
	1-stage	2-stage	1-stage	2-stage	1-stage	2-stage	1-stage	2-stage	1-stage	2-stage
D1	34		52		70		100		145	
D2	M4X9		M5X10		M6X12		M10X18		M12X22	
D3	h6	10	14	20	25	40	55	87	125.5	173
D4	h7	26	40	60	80	130	182.5	230		
D5	17		17		30		40		55	
D6	M3X0.5P		M5X0.8P		M6X1P		M10X1.5P		M16X2P	
D8	44		60		86		114		160	
L2	26		35		40		55		87	
L3	2		3		3		4		5	
L4	1		2		3.5		5		5.5	
L5	18		25		28		40		65	
L6	2.5		2.5		4		5		8	
L9	2.6		4.8		5		7.5		12	
L10	9		12.5		16.5		22		36	
L11	53	68	66.5	86.5	76.5	103	104	140	125.5	173
L12	78	93	96	116	116.5	143	155	191	182.5	230
B1	h9	3	5	6	8	12				
H1	11.2		16		22.5		28		43	

(1) Dimensions are related to motor interface. Please contact APEX for details.

# Selection of the optimum gearbox

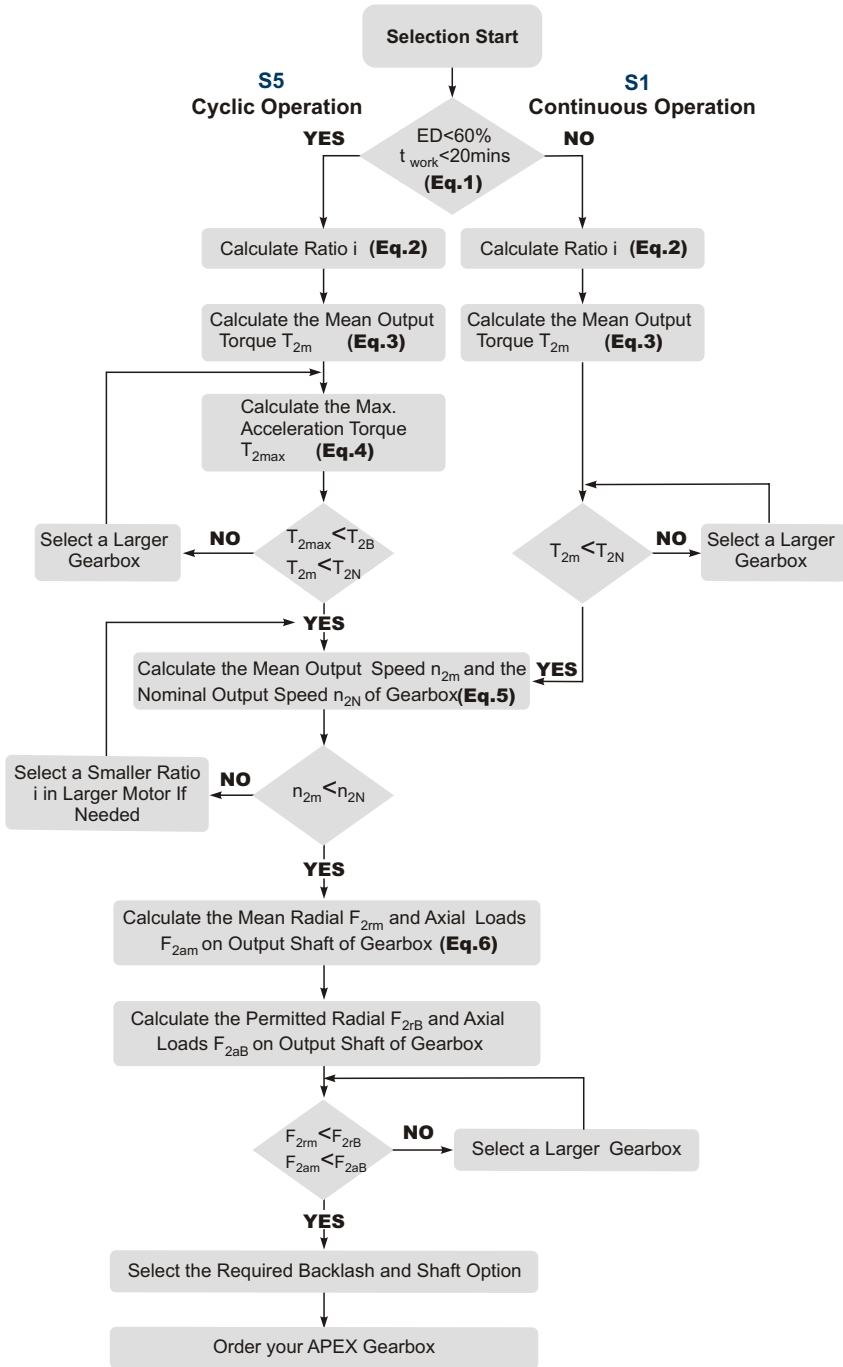

**Recommended (for S5 Cycle Operation)**

The general design is given for

$$\frac{J_L}{i^2} \leq 4 \times J_m$$

The optimal design is given for

$$\frac{J_L}{i^2} \cong J_m$$

$J_L$  Load Inertia

$J_m$  Motor Inertia

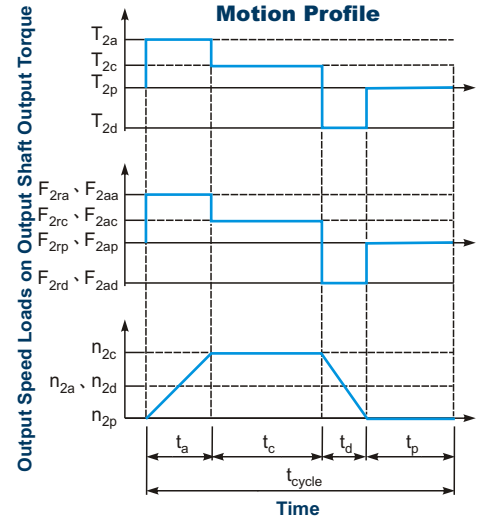

$$1. ED = \frac{t_a + t_c + t_d}{t_{cycle}} \times 100\%, t_{work} = t_a + t_c + t_d$$

Index : a. Acceleration, c. Constant,  
d. Deceleration, p. Pause **(Eq.1)**

$$2. i \cong \frac{n_m}{n_{work}}$$

$n_m$  Output Speed of the Motor  
 $n_{work}$  Working Speed **(Eq.2)**

$$3. T_{2m} = 3 \sqrt{\frac{n_{2a} \times t_a \times T_{2aa}^3 + n_{2c} \times t_c \times T_{2ac}^3 + n_{2d} \times t_d \times T_{2ad}^3}{n_{2a} \times t_a + n_{2c} \times t_c + n_{2d} \times t_d}}$$

**(Eq.3)**

4.  $T_{2max} = T_{mB} \times i \times K_s \times \eta$

where  $K_s$  is

$K_s$	No. of Cycles / hr
1.0	0 ~ 1,000
1.1	1,000 ~ 1,500
1.3	1,500 ~ 2,000
1.6	2,000 ~ 3,000
1.8	3,000 ~ 5,000

$T_{mB}$  Max. Output Torque of the Motor  
 $\eta$  Efficiency of the Gearbox **(Eq.4)**

$$5. n_{2a} = n_{2d} = \frac{1}{2} \times n_{2c}$$

$$n_{2m} = \frac{n_{2a} \times t_a + n_{2c} \times t_c + n_{2d} \times t_d}{t_a + t_c + t_d}$$

$$n_{2N} = \frac{n_{1N}}{i}$$

**(Eq.5)**

$$6. F_{2rm} = 3 \sqrt{\frac{n_{2a} \times t_a \times F_{2ra}^3 + n_{2c} \times t_c \times F_{2rc}^3 + n_{2d} \times t_d \times F_{2rd}^3}{n_{2a} \times t_a + n_{2c} \times t_c + n_{2d} \times t_d}}$$

$$F_{2am} = 3 \sqrt{\frac{n_{2a} \times t_a \times F_{2aa}^3 + n_{2c} \times t_c \times F_{2ac}^3 + n_{2d} \times t_d \times F_{2ad}^3}{n_{2a} \times t_a + n_{2c} \times t_c + n_{2d} \times t_d}}$$

**(Eq.6)**

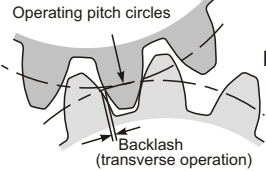
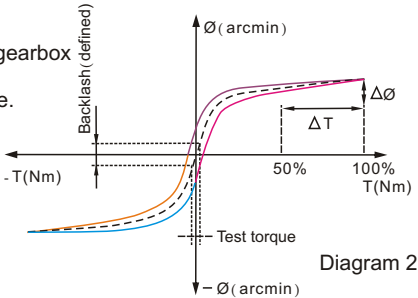
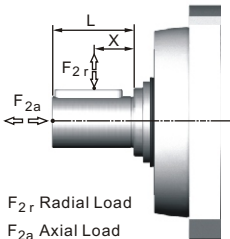

# Glossary

Emergency Stop Torque $T_{2NOT}$	Nm	The Emergency Stop Torque is the maximum permitted torque at the output of gearbox. This may happen only occasionally and may not exceed 1,000 times during the whole service life.
Max. Acceleration Torque $T_{2B}$	Nm	Under the Cyclic Operation (S5), the Max. Acceleration Torque is the maximum torque which can be transmitted only briefly to the output of gearbox up to 1,000 cycles/hr.
No Load Running Torque	Nm	The No Load Running Torque is the min. torque to overcome the internal friction of a gearbox without loading*.
Nominal Input Speed $n_{1N}$	rpm	The Nominal Input Speed is the permitted input speed of gearbox by the Continuous Operation (S1) while the housing temperature does not exceed 90°C. This value is measured at environment temperature 25°C.
Max. Input Speed $n_{1B}$	rpm	The Max. Input Speed is the max. permitted input speed of gearbox by the Cyclic operation (S5). This value is measured at environment temperature 25°C and serves as the absolute limit of the gearbox.
Backlash	arcmin	<p>The Backlash is the maximum angular measurement between two teeth of gears when the transverse operation occurs (refer to Diagram 1). The arcmin is the measurement unit for the backlash. One arcmin equals 1/60 degree, symbolized as 1'.</p> 
Torsional Rigidity	Nm/arcmin	<p>Torsional Rigidity is the quotient (<math>\Delta T / \Delta \theta</math>) between the applied torque and resulting torsion angle. This value indicates how much torque is needed on the gearbox to rotate the output shaft for 1 arcmin. The Torsional Rigidity can be determined by Hysteresis Curve.</p> <p>Hysteresis Curve When the input shaft is locked, increase torque at the output slowly up to <math>T_{2B}</math> in both directions and then release the torque gradually. According to the measured torque and torsion angle, a closed curve will be acquired as in the Diagram 2.</p> 
Radial Load And Axial Load	N	<p>The permitted radial and axial loads on output shaft of the gearbox depend on the design of the gearbox supporting bearings.</p> <p>For more information, please refer to APEX website.</p> 
Efficiency $\eta$	%	The transmission efficiency of the gears inside a gearbox (without friction).
Operating Temperature	°C	The Operating Temperature indicates the temperature of gearbox housing.
Degree of Protection		IP code stands for International Protection standard. The IP65 as example: the first IP number stands for protection degree against dust; the second IP number stands for protection against liquid.
Lubrication		APEX uses synthetic lubrication grease. Alternate greases are available, please contact APEX.
Running Noise	dB(A)	The Running Noise is measured depends on gearbox size, the ratio and the speed*. Higher speed usually induces higher noise level, while higher ratio induces lower noise level.
Moment of Inertia $J_1$	kg.cm <sup>2</sup>	The Moment of Inertia $J_1$ is a measurement of the effort applied to an object to maintain its momentary condition at rest or rotating.
Breakaway Torque	Nm	The Breakaway Torque is the minimum torque to start the rotation from the input side of gearbox. A smaller size or a higher ratio gearbox requests less Breakaway Torque.
Back Driving Torque	Nm	The Back Driving Torque is the minimum torque to start the rotation from the output side of gearbox. A larger size or a higher ratio gearbox requires greater Back Driving Torque.

\* This value is measured at environment temperature 25°C and the input speed 3,000 rpm. If the Nominal Input Speed  $n_{1N}$  of gearbox is over 3,000 rpm, this value is measured by that specific Nominal Input Speed.

# Contact Us

## ASIA

### Northern Taiwan

ANDTEK AUTOMATION CO.,LTD  
 TEL: +886-2-82262655  
 FAX: +886-2-82262660  
 ADD: 12F-2, No.2, Jian 8th Rd., Zhonghe Dist., New Taipei City 235, Taiwan (R.O.C)  
 E-Mail: sales@andtek.com.tw  
 WebSite: www.apexdyna.com

### Central Taiwan

ANDTEK AUTOMATION CO.,LTD  
 TEL: +886-4-23594286  
 FAX: +886-4-23594262  
 ADD: 9F-6, No.925, Sec.4, Taiwan Blvd., Xitun Dist., Taichung City 407, Taiwan (R.O.C.)  
 E-Mail: sales@andtek.com.tw  
 WebSite: www.apexdyna.com

### Southern Taiwan

MEN JENN ELECTRIC CO., LTD.  
 TEL: +886-6-2337332-6  
 FAX: +886-6-2336214  
 ADD: No.744, Zhunghua Rd., Yongkang Dist., Tainan City 710, Taiwan (R.O.C)  
 E-Mail: menjenn@ms24.hinet.net  
 WebSite: www.apexdyna.com

### China - Shanghai

APEX DYNAMICS INC. SHANGHAI  
 TEL: +86-21-69220577  
 FAX: +86-21-69220571  
 ADD: No.128, ZhuYing Rd., QingPu Industry Area, Shanghai, China  
 E-Mail: sales@apexdyna.cn  
 WebSite : www.apexdyna.cn

### China - Beijing

APEX DYNAMICS BEIJING,LTD.  
 TEL: +86-10-69570691  
 FAX: +86-10-69570641  
 ADD: No.1, YaoPing Rd., SongZhuang Town, Tongzhou Dist., Beijing, China.  
 E-Mail: bjapexdyna@163.com  
 WebSite: www.bjapexdyna.net

### China - Chongqing

CHONGQING APEX DYNAMICS CO., LTD  
 TEL: +86-23-67686860  
 FAX: +86-23-67686872  
 ADD: 406, Building 5, No.68, Jinyu Avenue,Beibu New Area, Chongqing, China  
 E-Mail: sales@cqapexdyna.com  
 WebSite: www.apexdyna.com

### China - Shenzhen

APEX DYNAMICS SHENZHEN, LTD  
 TEL: +86-755-84516325  
 FAX: +86-755-28228712  
 ADD: No. 1102A of D area, CFG mansion, Bao Yuan Road, Bao' an District, Shenzhen, China.  
 E-Mail: Sales@szapexdyna.com  
 WebSite: www.szapexdyna.com

### China - Xiamen

APEX(XIAMEN)DYNAMICS TECHNOLOGY CO.,LTD.  
 TEL: +86-592-720-5279  
 FAX: +86-592-720-5277  
 ADD: Unit B-3, 1F., No.129, Jingquan Road, Jimei District, Xiamen, Fujian, China, PC:361021  
 E-Mail: sales@xmapexdyna.com  
 WebSite: www.xmapexdyna.com

### Korea

APEX DYNAMICS KOREA  
 TEL: +82-31-8179992-3  
 FAX: +82-31-8179996  
 ADD: 1246-32, Seongsuk-dong, Ilsandong-gu, Goyang-city, Gyeonggi-Do, Korea (R.O.K) 410-570  
 E-Mail: sales@apexdynakorea.co.kr  
 WebSite: www.apexdynakorea.co.kr

### Japan

APEX DYNAMICS JAPAN  
 TEL: +81-92-4511202  
 FAX: +81-92-4511106  
 ADD: 1-13-3, Sannou, Hakata-ku, Fukuoka-shi 812-0015, Japan  
 E-Mail: sales@apexdyna.jp  
 WebSite: www.apexdyna.jp

### Thailand

APEX DYNAMICS (THAILAND) CO., LTD.  
 TEL: +66-2-3266233  
 FAX: +66-2-3266235  
 ADD: 73 Soi Ladkrabang 30, Kadkrabang Rd.,Bangkok 10520, Thailand  
 E-Mail: sales@apexdyna.co.th  
 WebSite: www.apexdyna.co.th

### Singapore, Malaysia

APEX DYNAMICS SINGAPORE PTE LTD  
 TEL: +65-62-626228  
 FAX: +65-62-626282  
 ADD: No.1, Bukit Batok Crescent, #09-51, WCEGA Plaza, Singapore 658064  
 E-Mail: sales@apexdyna.com.sg  
 WebSite: www.apexdyna.com.sg

### Indonesia

PT.APEX DYNAMICS INDONESIA  
 TEL: +62-21-26859971  
 FAX: +62-21-26859973  
 ADD: Ruko Aralia Blok HY43 no.11, Harapan Indah II, Bekasi - Jawa Barat, Indonesia 17214  
 E-Mail: sales@apexdyna.co.id  
 WebSite: www.apexdyna.co.id

### Australia

APEX DYNAMICS AUSTRALIA PTY LTD.  
 TEL: +613-95-852739  
 FAX: +613-95-852731  
 ADD: 36 Taunton Drive,Cheltenham, Victoria 3192, Australia  
 E-Mail: sales@apexdyna.com.au  
 WebSite: www.apexdyna.com.au

### India

APEX DYNAMICS (I) JV  
 TEL: +91-20-3234-5541  
 FAX: +91-20-2431-7310  
 ADD: Gat No. 279, Khed Shivapur Baug, Taluka Haveli, Pune - 412205, India  
 E-Mail: sales@apexdyna.co.in  
 WebSite: www.apexdyna.co.in

### Iran

APEX DYNAMICS IRAN.  
 TEL: +98-21-66591180  
 FAX: +98-21-66593520  
 ADD: APT#4, No. 5, Kowsar 3rd St., Sattarkhan Ave., Tehran 1457683891, Iran  
 E-Mail: info@apexdyna.ir  
 WebSite: www.apexdyna.ir

### Turkey

APEKS REDUKTOR VE DISLI SAN. TIC. LTD. STI.  
 TEL: +90-232-4589960  
 FAX: +90-232-4589980  
 ADD: 1203/12 Sok. No:2/A Yenisehir Izmir-Turkey  
 E-Mail: sales@apexdyna.com.tr  
 WebSite: www.apexdyna.com.tr

## EUROPE

### Czech

APEX DYNAMICS CZECH S.R.O.  
TEL: +420-577-663877  
FAX: +420-577-663877  
ADD: tř. Tomáše Bati 1851 765 02 Otrokovice Česká republika  
E-Mail: info@apexdynaczech.cz  
WebSite: www.apexdynaczech.cz

### France

APEX DYNAMICS FRANCE SAS  
TEL: +33-169-853884  
FAX: +33-160-190090  
ADD: 11 - Burospace F - 91570 - Bièvres  
E-Mail: apexdyna.fr@gmail.com  
WebSite: www.apexdyna.fr

### Germany

APEX DYNAMICS GERMANY GMBH  
TEL: +49-7181-9329955  
FAX: +49-7181-880564  
ADD: Im Rank 10 D-73655 Pluderhausen  
E-Mail: Langer@apexdynamicsgermany.eu  
WebSite: apexdynamicsgermany.com

### Netherlands, Belgium, Luxembourg

APEX DYNAMICS BV  
TEL: +31-492-509995  
FAX: +31-492-509997  
ADD: Churchillaan 101 5705 BK HELMOND, THE Netherlands  
E-Mail: sales@apexdyna.nl  
WebSite: www.apexdyna.nl / www.apexdyna.be

### Poland

APEX DYNAMICS POLSKA SP. Z O.O.  
TEL: +48-12-6304728  
FAX: +48-12-6304750  
ADD: U1. Krakowska 50, 32-083 Balice / Krakow, Poland  
E-Mail: sales@apexdyna.pl  
WebSite: www.apexdyna.pl

### Russia

APEX DYNAMICS RUSSIA  
TEL: +7-495-2255452  
FAX: +7-495-2255452  
ADD: Floor 3, bld. 83, Ugreshskaya str. 2, Moscow, 115088, Russia  
E-Mail: sale@giden.ru  
WebSite: www.giden.ru

### Sweden

APEX DYNAMICS SWEDEN AB  
TEL: +46-75-2424444  
FAX: +46-75-2424449  
ADD: Fredrikbergsgatan 2 SE-573 92 Tranås  
E-Mail: sales@apexdyna.se  
WebSite: www.apexdyna.se

### Spain, Portugal

APEX DYNAMICS SPAIN, S.L.  
TEL: +34-93-6562990  
FAX: +34-93-6561268  
ADD: Poligono Industrial Molí dels Frares, Calle C nº 12, 08620 - Sant Vicenç dels Horts, Barcelona, Spain  
E-Mail: apexdyna@apexdyna.es  
WebSite : www.apexdyna.es

### UK, Ireland

APEX DYNAMICS UK LIMITED  
ADD: 2 Centurion Way, Centurion Park, Tamworth Staffs, B77 5PN  
TEL: +44-1827-253340  
FAX: +44-1827-253390 / +44-1827-253391  
E-mail: sales@apexdynamicsuk.com  
Website: www.apexdynamicsuk.com

## AMERICA

### USA

APEX DYNAMICSUSA, INC.  
TEL: +1-631-2449040  
FAX: +1-631-2449030  
ADD: 885 Marconi Avenue, Ronkonkoma, NY 11779, U.S.A.  
E-Mail: sales@apexdynamicsusa.com  
WebSite: www.apexdynamicsusa.com

### Brazil

NEOYAMA  
TEL: +55-47-30298700  
FAX:  
ADD: Rua Senador Petrônio Portela, 47 - Bloco 5, Zona Industrial Norte - CEP 89218-575 - Joinville (SC)  
E-Mail: leonardo.frade@neoyama.com.br  
danny.e@neoyama.com.br  
WebSite: www.neoyama.com.br



**29 APEX Agents in 23 countries  
worldwide, sincerely at your service!**



## **APEX DYNAMICS, INC.**

No. 10, Keyuan 3rd Road, Situn District, Taichung City 407, Taiwan R.O.C

TEL: 886-4-24650219 / FAX: 886-4-24650118

E-Mail: [sales@apexdyna.com](mailto:sales@apexdyna.com) Website: <http://www.apexdyna.com/>

**APEX-2014-12-PII/PIIR SERIES-1.0E-1.0V**

